

MALERSCHABLONE, Rand 3cm

Diese Berechnungsbeispiele dienen zur Orientierung und sind **keine** Pauschalpreise.
 Der Preis für dein individuelles Motiv wird automatisch in unserem Konfigurator berechnet (siehe Seite 2).

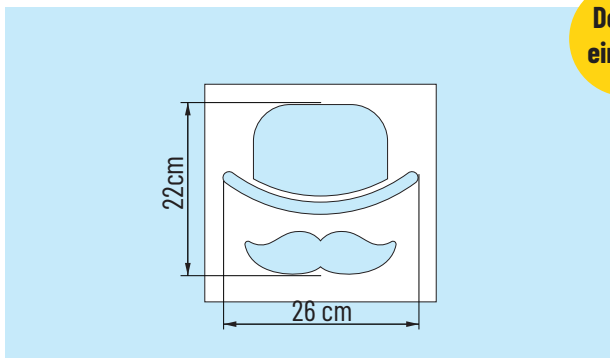

**Detail:
einfach**

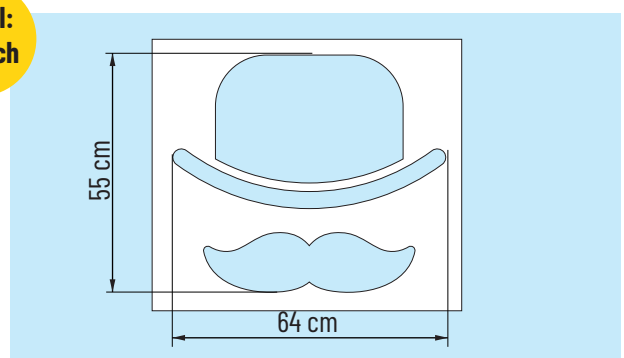

Motiv:	26 x 22 cm			
Stück:	1	2	3	10
Preis/Stk.:	27€	16€	12€	9€

Motiv:	64 x 55 cm			
Stück:	1	2	3	10
Preis/Stk.:	53€	39€	35€	29€

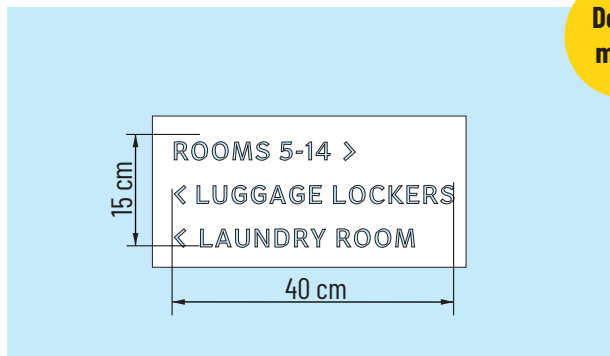

**Detail:
mittel**



Motiv:	40 x 15 cm			
Stück:	1	2	3	10
Preis/Stk.:	38€	24€	20€	15€

Motiv:	97 x 37 cm			
Stück:	1	2	3	10
Preis/Stk.:	64€	48€	43€	35€

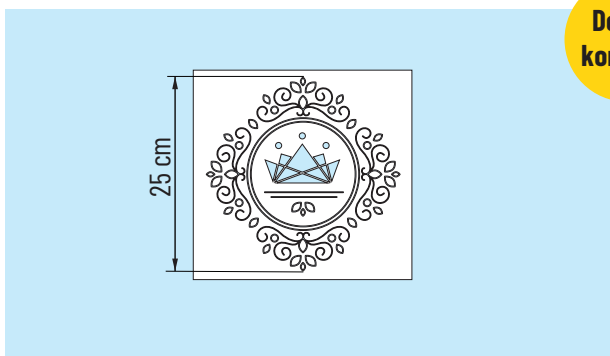



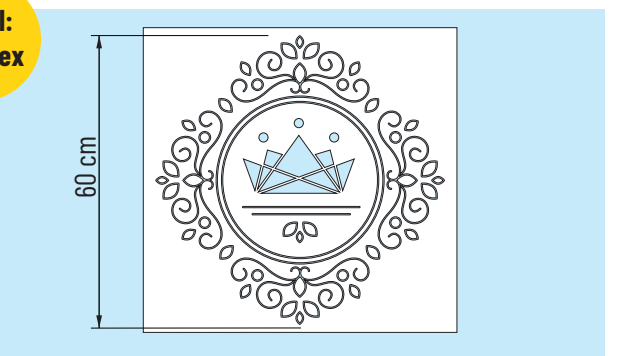



**Detail:
komplex**









Motiv:	25 x 25 cm			
Stück:	1	2	3	10
Preis/Stk.:	43€	29€	24€	19€

Motiv:	60 x 60 cm			
Stück:	1	2	3	10
Preis/Stk.:	75€	57€	52€	44€

*Der minimale Warenkorbwert für diese Produktgruppe liegt bei 30€
 Zusatzinformationen zu den Details siehe Seite 2 Online- Sofortpreisberechnung

<h2>Motiv</h2> <p>Ist dein Motiv sehr komplex, müssen sehr viele Konturen geschnitten werden. Bei Schablonen z.B. fallen viele Stege an. Dies erhöht die Maschinenlaufzeit und damit den Preis.</p> <div style="display: flex; justify-content: space-around;"> <div style="text-align: center;">  <p>komplex</p> <p>€€€</p> </div> <div style="text-align: center;">  <p>mittel</p> <p>€€</p> </div> <div style="text-align: center;">  <p>einfach</p> <p>€</p> </div> </div>	<h2>Größe</h2> <p>Du kannst dein Motiv bei uns in der Größe beliebig anpassen. Von z.B. 2 x 5 cm bis zu mehreren Quadratmetern ist alles möglich. Je nach Produkt (Material) ist der Einfluss auf den Preis größer oder kleiner.</p> <div style="display: flex; justify-content: space-around;"> <div style="text-align: center;">  <p>groß</p> <p>€€€</p> </div> <div style="text-align: center;">  <p>mittel</p> <p>€€</p> </div> <div style="text-align: center;">  <p>klein</p> <p>€</p> </div> </div>
-------------------------------------------------------------------------------------------------------------------------------------------------------------------------------------------------------------------------------------------------------------------------------------------------------------------------------------------------------------------------------------------------------------------------------------------------------------------------------------------------------------------------------------------------------------------------------------------------------------------------------------------------------------------------------------------------------------------------------------------------------------------	-----------------------------------------------------------------------------------------------------------------------------------------------------------------------------------------------------------------------------------------------------------------------------------------------------------------------------------------------------------------------------------------------------------------------------------------------------------------------------------------------------------------------------------------------------------------------------------------------------------------------------------------------------------------------------------------------------------------------------------------------------------------------------------------------

Wie berechnet sich der Preis? 

<h2>Stückzahl</h2> <p>Einzelstück oder Großauflage mit 1.500 Zuschnitten? Kein Problem, der Preis wird bei der Anpassung der Stückzahl sofort automatisch neu berechnet. Profitiere von massiven Mengenrabatten.</p> <div style="display: flex; justify-content: space-around;"> <div style="text-align: center;">  <p>Einzelstück</p> <p>€€€</p> </div> <div style="text-align: center;">  <p>Kleinauflage</p> <p>€€</p> </div> <div style="text-align: center;">  <p>Großserie</p> <p>€</p> </div> </div>	<h2>Zeitoption</h2> <p>Bestimme selbst, wie schnell dein Auftrag produziert werden soll. Bei einer Expressproduktion/-lieferung wird es etwas teurer. Wenn du keinen Zeitdruck hast, kannst du sparen.</p> <div style="display: flex; justify-content: space-around;"> <div style="text-align: center;">  <p>Express</p> <p>€€€</p> </div> <div style="text-align: center;">  <p>Standard</p> <p>€€</p> </div> <div style="text-align: center;">  <p>Economy</p> <p>€</p> </div> </div>
--------------------------------------------------------------------------------------------------------------------------------------------------------------------------------------------------------------------------------------------------------------------------------------------------------------------------------------------------------------------------------------------------------------------------------------------------------------------------------------------------------------------------------------------------------------------------------------------------------------------------------------------------------------------------------------------------------------------------------------------------------------------------------------------------	----------------------------------------------------------------------------------------------------------------------------------------------------------------------------------------------------------------------------------------------------------------------------------------------------------------------------------------------------------------------------------------------------------------------------------------------------------------------------------------------------------------------------------------------------------------------------------------------------------------------------------------------------------------------------------------------------------------------------------------------------------------------------------